

H

TKV Series Filter Housings

Multi-Cartridge Filter Housings with an Innovative Sealing System Allowing Maximum Flexibility in a Wide Range of Applications

- 150 psig Maximum Operating Pressure Permits Use in a Wide Range of Application
- Innovative Sealing System Accepts Single Open End or Double Open End Cartridges Allowing Maximum Flexibility in Filter Cartridge Selection
- Housing Accepts Seven-10", 20", 30", 40" Cartridges Allowing Optimum System Design
- 304 or 316 Stainless Steel Materials of Construction for Maximum Corrosion Resistance
- Optional Electropolish Finish is Available
- Operator Friendly V-Clamp Closure Allows Quick and Easy Cartridge Change Out
- 3, 5, 7, 9 and 12 Round Models are Also Available



Housing Specifications

Materials of Construction:

	<u>A</u>	<u>S</u>
• Head:	304 Stainless Steel	316 Stainless Steel
• Shell:	304 Stainless Steel	316 Stainless Steel
• Vent Cap:	304 Stainless Steel	316 Stainless Steel
• Drain Plug:	304 Stainless Steel	316 Stainless Steel
• Bottom Seat Plate:	304 Stainless Steel	316 Stainless Steel
• Internal Components:	304 Stainless Steel	316 Stainless Steel
• Shell O-rings:	Standard: Optional:	EPDM Viton, Teflon Encapsulated Viton, Silicone

Connections:

- Inlet/Outlet: 1.5"~3" (48.3~88.9mm) NPT, ANSI Flange
- Vent: 1/4" (13.7mm) NPT
- Drain: 3/4" (26.7mm) NPT
- Optional Connection: JIS, DIN Flanged, PT, BSP

Performance Specifications

- Maximum Operating Pressure: 150 psig (10.3 bar) @ 200°F (93°C) in Liquid Service
(TKV Series Housings not Recommend for Gas Service)

Dimensional Data

Model	Liquid Flow Rate gpm (lpm)	Dimension Inches (mm)				Maximum Cartridge Diameter Inches (mm)	Weight lbs (kg)	Overhead Clearance Required for Cartridge Removal Inches (mm)
		A	B	C	D			
3TKV1-1.5	to 15 (57)	23.0" (584)	11.1" (283)	5.0" (128)	6" (165)	2.75" (70)	21.8 (9.9)	29.6" (752)
6TKV2-1.5	to 30 (114)	33.0" (838)	11.1" (283)	5.0" (128)	6" (165)	2.75" (70)	27.3 (12.4)	39.6" (1006)
9TKV3-1.5	to 60 (171)	43.0" (1092)	11.1" (283)	5.0" (128)	6" (165)	2.75" (70)	33.1 (15)	49.6" (1260)
5TKV1-2	to 25 (95)	23.5" (598)	11.1" (283)	5.0" (128)	8" (210)	2.75" (70)	33.1 (15)	19.8" (504)
10TKV2-2	to 50 (190)	33.5" (852)	11.1" (283)	5.0" (128)	8" (210)	2.75" (70)	39.2 (17.8)	29.8" (758)
15TKV3-2	to 75 (285)	43.5" (1106)	11.1" (283)	5.0" (128)	8" (210)	2.75" (70)	45.4 (20.6)	39.8" (1012)
20TKV4-2	to 100 (380)	54.0" (137)	11.1" (283)	5.0" (128)	8" (210)	2.75" (70)	53.1 (24.1)	59.8" (1520)
7TKV1-2	to 35 (133)	24.0" (607)	11.1" (283)	5.0" (128)	9" (232)	2.75" (70)	34.2 (15.5)	29.8" (758)
14TKV2-2	to 70 (266)	33.9" (861)	11.1" (283)	5.0" (128)	9" (232)	2.75" (70)	39.9 (18.1)	39.8" (1012)
21TKV3-2	to 100 (375)	43.9" (1115)	11.1" (283)	5.0" (128)	9" (232)	2.75" (70)	46.1 (20.9)	49.8" (1266)
28TKV4-2	to 125 (470)	54.3" (1379)	11.1" (283)	5.0" (128)	9" (232)	2.75" (70)	53.8 (24.4)	60.2" (1530)
27TKV3-2.5	to 135 (513)	47.9" (1216)	14.6" (370)	6.3" (159)	10" (268)	2.75" (70)	48.7 (22.1)	73.7" (1872)
36TKV4-2.5	to 180 (684)	58.3" (1480)	14.6" (370)	6.3" (159)	10" (268)	2.75" (70)	56.4 (25.6)	94.1" (2390)
36TKV3-3	to 210 (794)	46.5" (1180)	13.0" (330)	6.7" (170)	12" (312)	2.75" (70)	54.0 (24.5)	52.1" (1323)
48TKV4-3	to 240 (912)	56.5" (1434)	13.0" (330)	6.7" (170)	12" (312)	2.75" (70)	59.5 (27)	62.1" (1577)

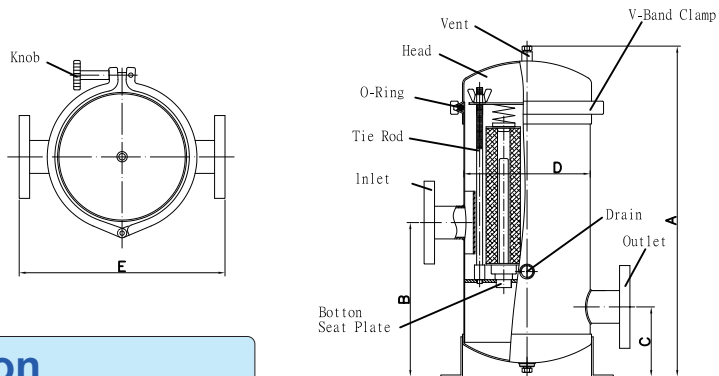

Ordering Information

14 No. of 10" Equiv	TKV Product Name	2 No. of 10" Equiv. Per Column	A- Material of Construction	2 Inlet / Outlet Connection Size	F Connection Style	A- Connection Specification	3- Cartridge Type	EP Option
3, 6, 9, 5, 10, 15, 7, 14, 21, 27, 28, 36, 48	TKV	1 = 10" 2 = 20" 3 = 30" 4 = 40"	A = SS304 S = SS316	1.5 = 1.5" 2 = 2" 2.5 = 2.5" 3 = 3"	F = Flange T = Thread	A = ANSI J = JIS D = DIN N = NPT	DOE 3 = SOE with 222 O-rings, Flat Closed End 8 = SOE with 222 O-rings, Fin End 7 = SOE with 226 O-rings, Fin End	Electro Polished