



MSV Series High Flow Filter Housings

150 psig, Multi-Cartridge Industrial Filter Housings for High Flow Applications

- 150 psig Design Pressure Permits Use in a Wide Range of Applications
- Models Available to Accept 12 to 147 Round of 20", 30", 40", 50" Cartridges Allows for Optimum System Design
- 304, 316 and 316L Stainless Steel Materials of Construction
- Innovative Sealing System Accepts Single Open End or Double Open End Cartridges Allowing Maximum Flexibility in Filter Cartridge Selection
- Swing Eye Bolt Closure Design for Added Durability and Quick Cartridge Change-Out
- ASME Code Section VIII Division I, U Stamp Available
- Housings can be Designed for Reverse Flow Applications
- Higher Pressure or Customized Designs Available



Housing Specifications

Materials of Construction:

- Head and Shell: 304, 316 or 316L Stainless Steel
- Connections: 304, 316 or 316L Stainless Steel
- Internal Components: 304, 316 or 316 L Stainless Steel
- Swing Eye Bolts: 304 Stainless Steel or Zinc Carbon Steel
- Shell O-rings: Standard: EPDM
Optional: Viton, Teflon Encapsulated Viton, Silicone

Connections:

- Inlet/Outlet: 3"-12" (88.9mm – 323.9mm) ANSI Flanged
- Vent: 1" (33.4mm) NPT
- Drain: 1.5" (48.3mm) NPT
- Gauge: 1/4" (13.7mm) NPT
- Optional Connection: JIS, DIN Flanged

Performance Specifications

- Maximum Operating Pressure: 150 psig (10.3 bar) @200°F (93°C) in Liquid Service

Construction:

- Standard: Non Code
- Optional: ASME UM Stamp, ASME U Stamp

Dimensional Data

12 Columns	A	B	C	D	E	F	G	H	φP	Legs
24MSV2	54.8" (1391)	9.0" (228)	12" (305)	17.9" (455)	11.8" (300)	3" (88.9)	18.9" (480)	14" (355)	8.5" (216)	3
36MSV3	64.8" (1645)									
48MSV4	74.8" (1899)									
18 Columns	A									
36MSV2	55.4" (1407)	10" (253)	14" (355)	18.2" (462)	11.8" (300)	3" (88.9)	19.2" (487)	10.4" (264)	12.4" (314)	3
54MSV3	65.4" (1661)									
72MSV4	75.4" (1915)									
22 Columns	A									
44MSV2	58.8" (1494)	10.9" (278)	16" (406)	18.8" (478)	13.8" (350)	4" (114.3)	21.8" (553)	15.2" (385)	14.4" (365)	3
66MSV3	68.8" (1748)									
88MSV4	78.8" (2002)									
28 Columns	A									
56MSV2	59.6" (1513)	11.9" (303)	18" (456)	19.2" (488)	13.8" (350)	4" (114.3)	22.2" (563)	15.5" (394)	16.4" (417)	3
84MSV3	69.6" (1767)									
112MSV4	79.6" (2021)									
36 Columns	A									
72MSV2	64.6" (1640)	13" (328)	20" (506)	19.6" (498)	17.7" (450)	6" (168.3)	26.5" (673)	16.2" (411)	17" (431)	3
108MSV3	74.6" (1894)									
144MSV4	84.6" (2148)									
42 Columns	A									
84MSV2	66.1" (1684)	13.9" (354)	22" (558)	20" (512)	17.7" (450)	6" (168.3)	27" (687)	17.4" (441)	19" (481)	3
126MSV3	76.1" (1938)									
168MSV4	86.3" (2192)									
52 Columns	A									
104MSV2	67" (1702)	14.9" (379)	24" (608)	20.5" (520)	17.7" (450)	6" (168.3)	27.4" (695)	17.8" (451)	21" (534)	3
156MSV3	77" (1956)									
208MSV4	87" (2210)									
61 Columns	A									
122MSV2	68.1" (1731)	15.9" (404)	26" (658)	20.8" (529)	17.7" (450)	6" (168.3)	27.7" (704)	18.5" (471)	23" (584)	3
183MSV3	78.1" (1985)									
244MSV4	88.1" (2239)									

69 Columns	A	B	C	D	E	F	G	H	φP	Legs
138MSV2	72.9" (1851)	17.3" (439)	28" (710)	21.2" (539)	21.7" (550)	8" (219.1)	32" (814)	18.9" (481)	25.6" (650)	4
207MSV3	82.9" (2105)									
276MSV4	92.9" (2359)									
81 Columns	A									
162MSV2	74.1" (1883)	18.3" (465)	30" (762)	21.7" (551)	21.7" (550)	8" (219.1)	32.5" (826)	19.7" (501)	27.6" (702)	4
243MSV3	84.1" (2137)									
324MSV4	95.3" (2391)									
94 Columns	A									
188MSV2	74.9" (1903)	19.3" (490)	32" (810)	22.1" (561)	21.7" (550)	8" (219.1)	32.9" (836)	20.1" (511)	29.6" (754)	4
282MSV3	84.9" (2157)									
376MSV4	94.9" (2411)									
105 Columns	A									
210MSV2	80.6" (2048)	20.9" (531)	34" (862)	23.1" (586)	26" (660)	10" (273.1)	38.2" (971)	20.5" (521)	31.6" (803)	4
315MSV3	90.6" (2302)									
420MSV4	100.6" (2556)									
119 Columns	A									
238MSV2	83.3" (2116)	21.9" (556)	36" (912)	23.8" (605)	26" (660)	10" (273.1)	39" (990)	22.4" (570)	32.2" (819)	4
357MSV3	93.3" (2370)									
476MSV4	103.3" (2624)									
131 Columns	A									
262MSV2	88.5" (2247)	23.7" (601)	38" (962)	24.6" (626)	29.9" (760)	12" (323.9)	43.7" (1111)	22.8" (580)	34" (864)	4
393MSV3	98.5" (2501)									
524MSV4	108.5" (2755)									
147 Columns	A									
294MSV2	89.3" (2267)	24.7" (628)	40" (1016)	25" (636)	29.9" (760)	12" (323.9)	44.1" (1121)	23.2" (590)	36.1" (919)	4
441MSV3	99.3" (2521)									
588MSV4	109.3" (2775)									

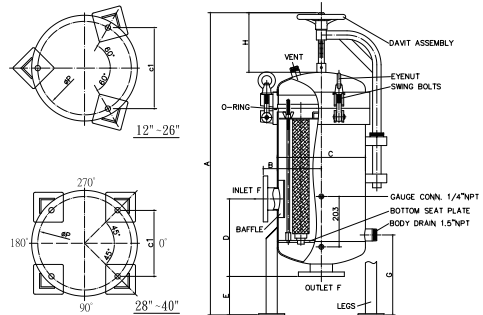

Ordering Information

36 No. of 10" Equiv	MSV Product Name	2- No. of 10" Equiv. Per Column	304- Material of Construction	3 Inlet / Outlet Connection Size	F Connection Style	D Davit Assembly	A- Flange Type	NC Code	150- Pressure Rating (psig)	3 Cartridge Type
24, 36, 54, 66, 108, 156, 276, ... 588	MSV	2 = 20" 3 = 30" 4 = 40" 5 = 50"	304 = 304SS 316 = 316SS 316L = 316LSS	3", 4", 6", 8", 10", 12"	F = Flange	Standard	A=ANSI J=JIS D=DIN	NC = Non Code UM = UM Stamp U = U Stamp	150	DOE 3 = SOE with 222 O-rings, Flat Closed End 8 = SOE with 222 O-rings, Fin End 7 = SOE with 226 O-rings, Fin End