

## MSB Series Multi-Bag Filter Housings

*150 psig, Multi-Bag Filter Housings for High Flow Applications*

- Eight Standard Sizes Available to Accommodate 2 to 12 Size #1 or #2 Filter Bags
- Available in 304, 316 or 316L Materials of Construction for Maximum Chemical and Temperature Compatibility
- Operator Friendly Swing Eye Bolts Design Allows Quick Filter Change-Out
- Positive O-Ring Sealing Design Minimizes the Chance of Fluid Bypass
- Optional Davit Arm with Hand Wheel, Hydraulic Lift Lids or Spring Assisted Lifted Device for Increased Ease of Use
- Housings can Accept Industry Standard Filter Bags Sizes or Filtrafine's Range of High Surface Area Filter Elements
- Custom Designs Available for Applications Requiring High Operating Pressures, Increased Chemical Compatibility or Special Inlet/Outlet Connections



### Housing Specifications

#### *Materials of Construction:*

- Shell: 304, 316, 316L Stainless Steel
- Leg /Swing Eye Bolts: Stainless Steel 304 or Zinc Carbon Steel
- Shell O-rings: Standard: EPDM  
Optional: Viton, Teflon Encapsulated Viton, Silicone

#### *Connections:*

- Inlet/Outlet: 3"-12" (88.9mm – 323.9mm) ANSI Flanged
- Vent: 1" (33.4mm) NPT
- Drain: 1.5" (48.3mm) NPT
- Gauge: 1/4" (13.7mm ) NPT
- Optional Connection: JIS, DIN Flanged

### Performance Specifications

- Maximum Operating Pressure: 150 psig (10.3 bar) @200°F (93°C) in Liquid Service

#### *Construction*

- Standard: Non-Code
- Optional: ASME UM Stamp,ASME U Stamp

## Dimensional Data

Model	Liquid Flow Rate gpm (m <sup>3</sup> / hr)	Dimensions Inches (mm)					
		A	B	C	D	E	F
2MSB1	to 175 (40)	39.5" (1004)	4.9" (125)	19.1" (485)	18" (457.2)	11.9" (303)	3"(88.9)
3MSB1	to 260 (60)	42.0" (1066)	5.7" (145)	20.1" (510)	20" (508.0)	13.0" (329)	4"(114.3)
4MSB1	to 350 (80)	43.3" (1099)	5.7" (145)	20.2" (513)	22" (558.8)	13.9" (354)	4"(114.3)
5MSB1	to 440 (100)	46.2" (1174)	6.7" (170)	21.8" (553)	24" (609.6)	16.7" (425)	6"(168.3)
6MSB1	to 525 (120)	48.6" (1234)	6.7" (170)	23.0" (583)	28" (711.2)	18.7" (475)	6"(168.3)
8MSB1	to 700 (160)	54.1" (1374)	8.1" (205)	25.9" (658)	32" (812.8)	21.9" (556)	8"(219.1)
10MSB1	to 880 (200)	59.1" (1502)	9.4" (240)	28.5" (720)	36" (914.4)	23.9" (608)	10"(273.1)
12MSB1	to 1050 (240)	61.9" (1572)	11.0" (280)	29.1" (740)	38" (965.2)	26.9" (683)	12"(323.9)
2MSB2	to 350 (80)	53.9" (1369)	4.9" (125)	33.5" (850)	18" (457.2)	11.9" (303)	3"(88.9)
3MSB2	to 525 (120)	56.3" (1431)	5.7" (145)	34.5" (875)	20" (508.0)	13.0" (329)	4"(114.3)
4MSB2	to 705 (160)	57.6" (1464)	5.7" (145)	34.6" (878)	22" (558.8)	13.9" (354)	4"(114.3)
5MSB2	to 880 (200)	60.6" (1539)	6.7" (170)	36.1" (918)	24" (609.6)	16.7" (425)	6"(168.3)
6MSB2	to 1055 (240)	63.0" (1599)	6.7" (170)	37.3" (948)	28" (711.2)	18.7" (475)	6"(168.3)
8MSB2	to 1405 (320)	68.5" (1739)	8.1" (205)	40.3" (1023)	32" (812.8)	21.9" (556)	8"(219.1)
10MSB2	to 1760 (400)	73.5" (1867)	9.4" (240)	42.7" (1085)	36" (914.4)	23.9" (608)	10"(273.1)
12MSB2	to 2110 (480)	76.3" (1937)	11.0" (280)	43.5" (1105)	38" (965.2)	26.9" (683)	12"(323.9)

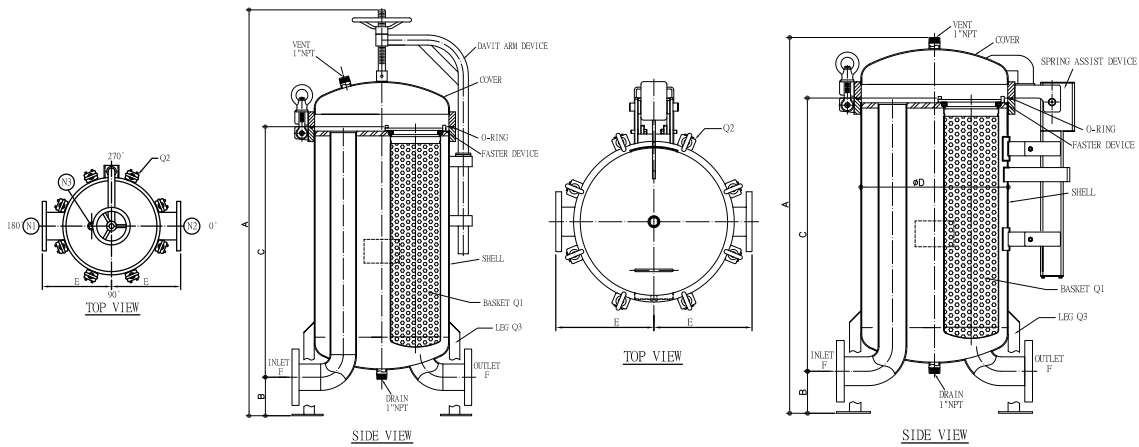

## Ordering Information

3 No. of Bag	MSB Product Name	2 - Bag Size	304 - Material of Construction	2 Inlet / Outlet Connection Size	F Connection Style	D Davit Arm Lifting	A - Flange Connection with	NC Code	150 - Pressure Rating (psig)
2, 3, 4, 5, 6, 8, 10, 12	MSB	1 = 01 2 = 02	A = 304 SS S = 316 SS SL = 316L SS	3" ~ 12"	F = Flange	S = Spring Assisted D = Davit Arm Lifting H = Hydraulic Assisted	A = ANSI Flange J = JIS Flange D = DIN Flange	Non Code	150