

MQB Series Rapid Open Multi-Bag Filter Housings

Multi-Bag Filter Housings with Rapid Open Closure Mechanism and Operator Friendly Spring Assisted Cover Lift; Ideal for Applications Requiring Frequent Change-Out

- Rapid Open Closure Mechanism Provides Quick and Easy Filter Change-Out. Designed Specifically for Processes Requiring Frequent Change-Out
- Spring Assisted Cover Lift is Operator Friendly and Eliminates the Needs for Tools During Filter Change-Out
- Low Profile Housing Design Allows Installation in Confined Spaces and Eliminates the Need for Ladders, Stools and Catwalks During Filter Change-Out
- Compact Housing Design Minimizes Product Loss During Change-Out
- Standard Sizes Available to Accommodate 3 to 12 Size #1 or #2 Filter Bags
- Positive O-Ring Sealing Design Provides Safe and Easy Operation
- Available in 304, 316 and 316L Materials of Construction for Maximum Chemical and Temperature Compatibility



Housing Specifications

Materials of Construction:

- Shell: 304, 316 and 316L Stainless Steel
- Leg /Rapid Open Closure: 304 Stainless Steel
- O-rings: Standard: EPDM
Optional: Viton, Teflon Encapsulated Viton, Silicone

Connections:

- Inlet/Outlet: 3"-12" (88.9mm – 323.9mm) ANSI Flanged
- Vent: 1" (33.4mm) NPT
- Drain: 1" (33.4mm) NPT
- Optional Connection: JIS, DIN Flanged

Performance Specifications

- Maximum Operating Pressure: 150 psig (10.3 bar) @200°F (93°C) in Liquid Service

Construction

- Standard: Non-Code
- Optional: ASME UM Stamp, ASME U Stamp

Dimensional Data

Model	Dimensions Inches (mm)					
	A	B	C	D	E	F
3MQB1 4MQB1	11.8"(300)	11.8" (300)	13.9" (354)	22"(558)	43.5" (1105)	4"(114.3)
5MQB1 6MQB1	11.8"(350)	13.8" (350)	18.7" (475)	28"(710)	49.4" (1255)	6"(168.3)
7MQB1 8MQB1	14.0"(355)	14.0" (355)	21.9" (556)	32"(810)	53.3" (1355)	8"(219.1)
10MQB1 12MQB1	11.8"(300)	11.8" (300)	26.9" (683)	38"(962)	54.5" (1385)	10"(273.1)
3MQB2 4MQB2	6.1"(155)	6.1" (155)	13.9" (354)	22"(558)	52.2" (1325)	4"(114.3)
5MQB2 6MQB2	7.1"(180)	7.1" (180)	18.7" (475)	28"(710)	57.1" (1450)	6"(168.3)
7MQB2 8MQB2	8.5"(215)	8.5" (215)	21.9" (556)	32"(810)	62.2" (1580)	8"(219.1)
10MQB2 12MQB2	9.8"(250)	9.8" (250)	23.0" (683)	38"(962)	66.9" (1700)	10"(273.1)

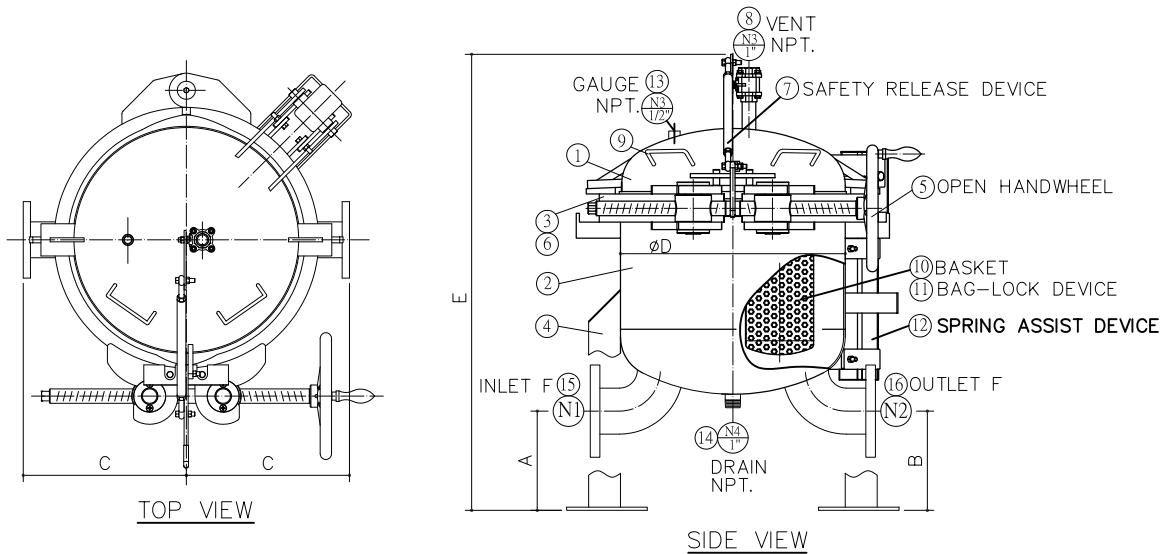

Ordering Information

3MQB Product Name/No. Of Bags	2 Bag Size	A - Material of Construction	2 Inlet / Outlet Connection Size	F Connection Style	S Lid Lifting	A - Flange Connection with	NC Code	150 - Pressure Rating (psig)
MQB, 3, 4, 5, 6, 7, 8, 10,12	1 = 01 2 = 02	A = 304 SS S = 316 SS SL= 316L SS	3" ~ 12"	F = Flange	S = Spring Assisted	A = ANSI Flange J = JIS Flange D = DIN Flange	NC = Non Code UM = UM Stamp U = U Stamp	150