

H

IDV-DOE Series Filter Housings

175 psig, Accepts Double Open End Cartridges, 316 Stainless Steel Construction

- Absolute Cartridge Sealing Design Eliminates Fluid Bypass
- Accepts 4", 10" and 20" Cartridge Lengths
- Operator Friendly Tri – Clamp Sealing Design Requires no Special Tools for Cartridge Change – Out
- Permits Visual Inspection of Cartridge Seal Before Closing the Housing
- Stainless Steel Tri – Clamp Bracket Allows Easy Cartridge Replacement



Housing Specifications

Materials of Construction:

- Head: 316 Stainless Steel
- Shell: 316 Stainless Steel
- Mounting Bracket: 304 Stainless Steel
- Gaskets/O-rings: Standard: Viton
Optional: Teflon Encapsulated Viton, EPDM

Connections:

- Inlet/Outlet: 3/4" (26.7mm), 1" (33.4mm) FNPT
- Vent/Gauge: 1/8" (10.3mm) NPT
- Drain: 1/4" (13.7mm) NPT

Performance Specifications

- Maximum Operating Pressure: 175 psig (12.1bar) @150°F (66°C)

Dimensional Data

Model	Liquid Flow Rate gpm (lpm)	Dimension Inches (mm)		Dry Weight lbs (kg)
		A	B	
IDV4S	to 4 (15.1lpm)	7.4" (189mm)	4.2" (106mm)	8.6lbs (3.9kg)
IDV10S	to 10 (37.9lpm)	13.4" (341mm)	4.2" (106mm)	10.1lbs (4.6kg)
IDV20S	to 20 (75.7lpm)	23.2" (591mm)	4.2" (106mm)	12.6lbs (5.7kg)

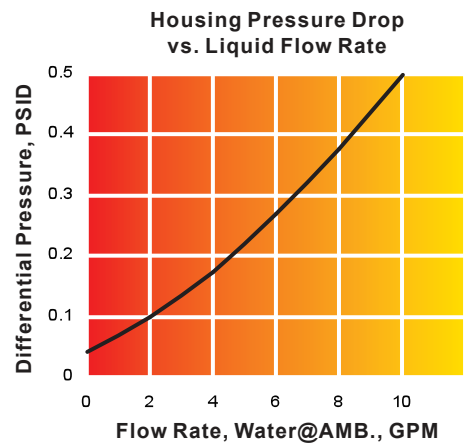
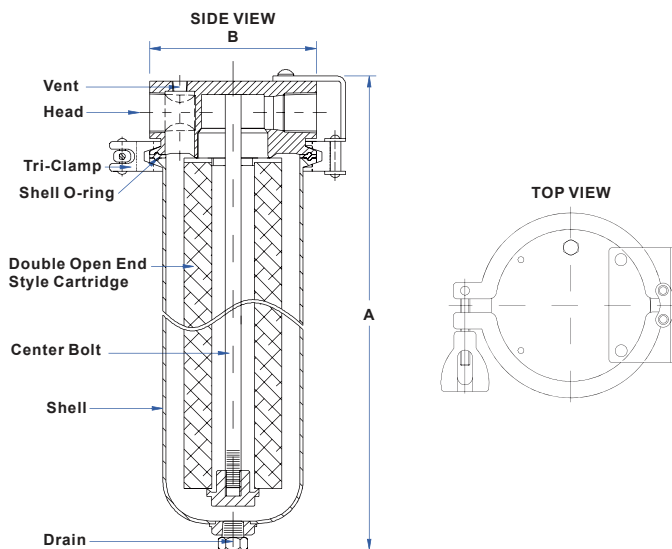

* For liquids other than water, multiply the pressure drop by the specific gravity of the fluid.

Ordering Information

IDV Product Name	10 Cartridge Length	S- Material of Construction	3/4- Inlet / Outlet Connection Size	CB- Tri-Clamp Bracket	DOE Cartridge Type
IDV	4 = 4" 10 = 10" 20 = 20"	S = 316SS	3/4 = 3/4"	CB= Tri-Clamp Bracket	DOE = Double Open End