

H

IDV- 3 Series Filter Housings

175 psig, Accepts 222 O-rings Flat Closed End Filter Cartridge, Electro-polished, 316 Stainless Steel

- Absolute Cartridge Sealing Design Eliminates Fluid Bypass
- Accepts 4", 10", 20" and 30" Cartridge Lengths
- Innovative Housing Design has no Internal Parts
- Tri-Clamp Sealing Design Requires no Special Tools for Cartridge Change-Out
- Tri-Clamp Design Minimizes Maintenance Cost by Allowing for Quick Opening and Closing of the Housing
- Permits Visual Inspection of Cartridge to Housing Seal Prior to Closing the Housing



Housing Specifications

Materials of Construction:

- Head: 316 Stainless Steel
- Shell: 316 Stainless Steel
- Mounting Bracket: 304 Stainless Steel
- Gaskets/O-rings: Standard: Viton
Optional: Teflon Encapsulated Viton, EPDM

Connections:

- Inlet/Outlet: 3/4" (26.7mm) , 1" (33.4mm) FNPT
- Vent/Gauge: 1/8" (10.3mm) NPT
- Drain: 1/4" (13.7mm) NPT

Performance Specifications

- Maximum Operating Pressure: 175 psig (12.1bar) @150°F (66°C)

Dimensional Data

Model	Liquid Flow Rate gpm (lpm)	Dimension Inches (mm)		Dry Weight lbs (kg)
		A	B	
IDV4S	to 4 (15.1lpm)	7.4" (189mm)	4.2" (106mm)	7.9lbs (3.6kg)
IDV10S	to 10(37.9lpm)	13.4 " (341mm)	4.2" (106mm)	9.3lbs (4.2kg)
IDV20S	to 20(75.7lpm)	23.2" (591mm)	4.2" (106mm)	11.2lbs (5.1kg)
IDV30S	to 30 (113.5lpm)	34.1" (866mm)	4.2" (106mm)	13.9lbs (6.3kg)

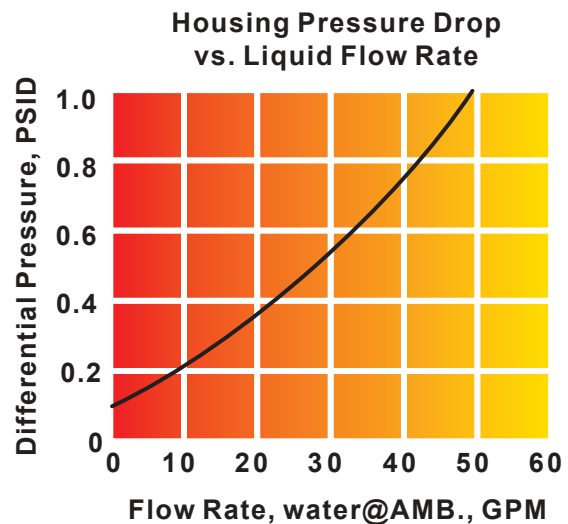
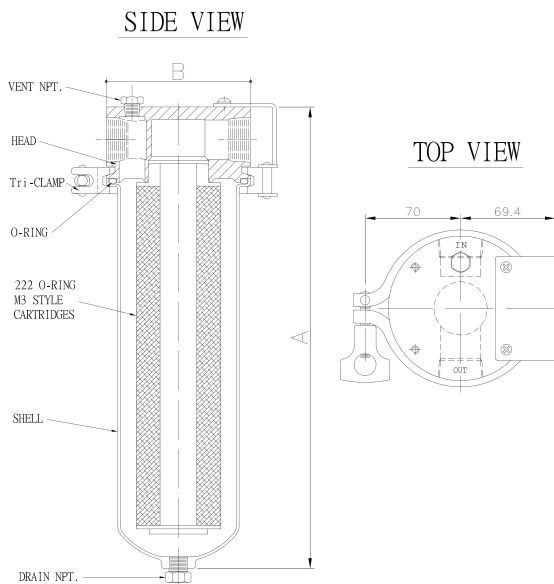

* For liquids other than water, multiply the pressure drop by the specific gravity of the fluid.

Ordering Information

IDV Product Name	10 Cartridge Length	S- Material of Construction	3/4- Inlet / Outlet Connection Size	CB- Tri-Clamp Bracket	3 Cartridge Type
IDV	4 = 4" 10 = 10" 20 = 20" 30 = 30"	S = 316SS	3/4 = 3/4" 1 = 1"	CB= Tri-Clamp Bracket	3 = Single Open End with 222 O-rings, Flat Closed End